

SHURFLO - Maxi Water Boost System

MAINTAINS CONSISTENT WATER PRESSURE FOR FOUNTAIN SYSTEMS

Maxi Water Boost:

804-026 115 VAC 1/2" (13 mm) Barb Fittings

804-037 115 VAC 3/8" (10 mm) Barb Fittings

Replacement Bladder: 94-697-00



APPLICATION

- Fountain
- Coffee
- Drinking water

FEATURES • BENEFITS

Increases flow and pressure to carbonated and non-carbonated soda valves for consistent drink quality

Maximizes filter life on filtration systems

Replaceable bladder for maximum system life and simple maintenance

Self-priming pump can run dry without damage

Eliminates pulsation at dispenser valve resulting in more accurate brix ratio and maximum syrup utilization

Low profile allows for undercounter installation

Rigid stainless steel tanks

Complete turn-key package

Replaceable bladder

Quick connects

NSF® Certified

INSTALLATION TIPS

Must be installed BEFORE the water filtration

Charge tank precharge at time of installation is at 50 psi (3.4 bar)

Check precharge each service visit to ensure optimum performance

Do not charge accumulator tank with CO₂

Use NSF listed high pressure braided tubing for inlet/outlet port (not included)

SIZING

Max. Working Pressure: 117 psi (8 bar).

Ports: 804-026 - 1/2" (13 mm) barb

804-037 - 3/8" (10 mm) barb inlet/outlet

SHURFLO - Maxi Watr Boost System

804-037

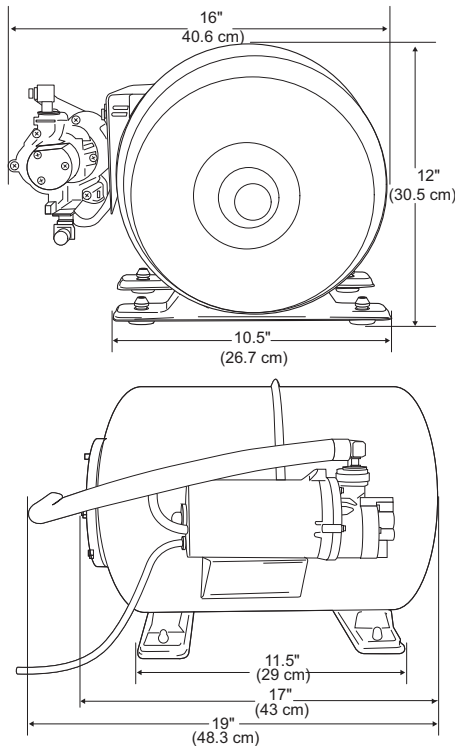

SPECIFICATIONS

Booster Pump

SHURflo 90 psi 115 VAC 8000 series corded pump (NSF, UL, CUL listed)

Accumulator Tank

6 gallon (22.7 L) SS and butyl rubber bladder (NSF listed)

Ports

804-026: 1/2" (13 mm) barb

804-037: 3/8" (10 mm) barb inlet/outlet

Pre-charge

W/air at installation.

50 psi (3.4 bar) (recommended for most beverage applications)

Draw Down Volume

3.1 gallons @ 50 psi (11.7 L @ 3.4 bar)

Dimensions

12" H x 19" W x 16" D (30.5 x 48.3 x 40.6 cm)

Electrical

115 Vac

Max. Working Pressure

117 psi (8 bar)

Temperature Limits

34 - 120°F (1.1 - 4.9°C)

Weight

18 pounds (8.1 kg) (empty)

WARRANTY

Limited Pentair® Warranty is valid from the date of manufacture or with proof of purchase:

2088 - One year

Water Boost - One year

Water Pressure Reducer Vale - One year

8000, 8025, 8010, 8075, 8095 - One year

Pentair will provide a copy of the warranty upon request.



FILTRATION & PROCESSING SOLUTIONS

EVERPURE-SHURFLO WORLD HEADQUARTERS 640 MUIRFIELD DRIVE, HANOVER PARK, IL 60133 USA • WWW.EVERPURE.COM
800.942.1153 MAIN (US ONLY) • 630.307.3000 MAIN • 630.307.3030 FAX • CSEVERPURE@PENTAIR.COM EMAIL

EVERPURE-SHURFLO AUSTRALIA / NEW ZEALAND 21 MONASH DRIVE, DANDENONG SOUTH, VIC, 3175, AUSTRALIA
1300.576.190 TEL • AU.EVERPURE@PENTAIR.COM EMAIL

EVERPURE-SHURFLO CHINA 21F CLOUD 9 PLAZA, NO 1118, SHANGHAI, 200052, CHINA
86.21.3211.4588 TEL • 86.21.3211.4580 FAX • CHINA.WATER@PENTAIR.COM EMAIL

EVERPURE-SHURFLO INDIA GREEN BOULEVARD, B-9/A, 7TH FLOOR - TOWER B SECTOR 62, NOIDA - 201301
91.120.419.9444 TEL • 91.120.419.9400 FAX • INDIACUSTOMER@PENTAIR.COM EMAIL

EVERPURE-SHURFLO EUROPE PENTAIR WATER BELGIUM BVBA, INDUSTRIEPARK WOLFSTEE, TOEKOMSTLAAN, 30 B-2200 HERENTALS, BELGIUM
+32.(0).14.283.500 TEL • +32.(0).14.283.505 FAX • SALES@EVERPURE-EUROPE.COM EMAIL

EVERPURE-SHURFLO JAPAN INCHASHIMOTO MN BLDG. 7F, 3-25-1 HASHIMOTO, MIDORI-KU, SAGAMIHARA-SHI KANAGAWA 252-0143, JAPAN
81.(0)42.775.3011 TEL • 81.(0)42.775.3015 FAX • INFO@EVERPURE.CO.JP EMAIL

EVERPURE-SHURFLO SOUTHEAST ASIA 30 HAVELOCK ROAD, #04-01, KING'S CENTRE, SINGAPORE 169662
65.6795.2213 TEL • FAX: 65.6795.2219 FAX • CSEVERPURE@PENTAIR.COM EMAIL

All Pentair trademarks and logos are owned by Pentair, Inc. All other brand or product names are trademarks or registered marks of their respective owners. Because we are continuously improving our products and services, Pentair reserves the right to change specifications without prior notice. Pentair is an equal opportunity employer.

© 2014 Pentair Filtration Solutions, LLC



Soluções de Filtragens e Processos

ASSTEFIL Indústria e Comércio de Filtros

Avenida Rangel Pestana, 117 • Jardim Cristiane • Santo André • SP

www.asstefil.com.br • suporte@asstefil.com.br • +55.11.4426-1075

Distribuidor autorizado no Brasil da:

